

NUOMI

Installation Instruction

○ Preview

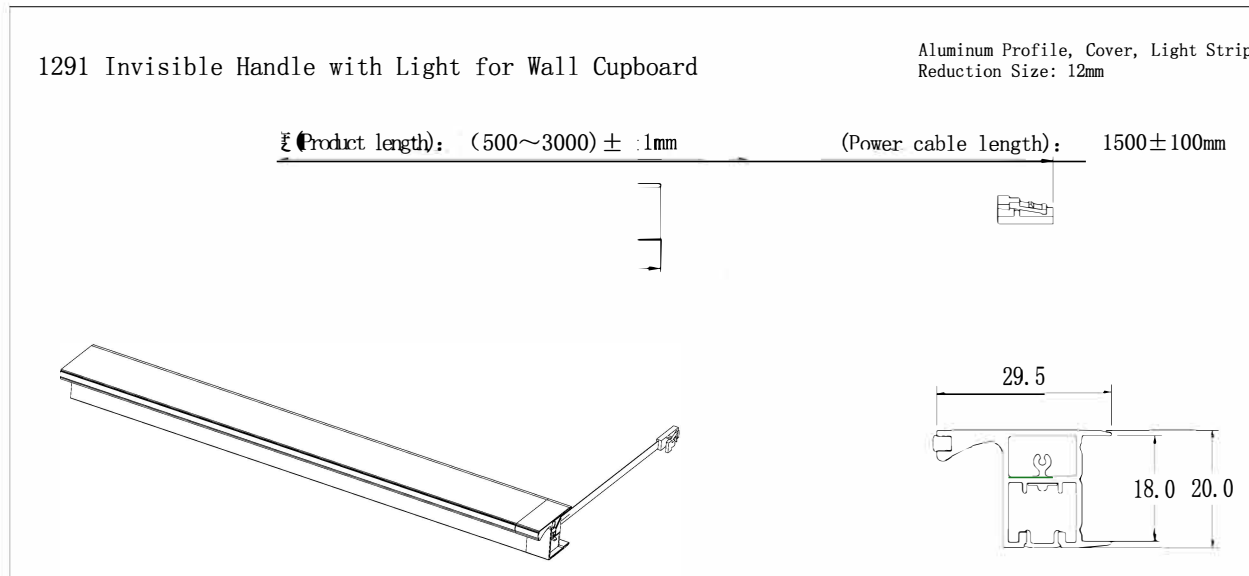

○ Parts List



○ Product Specifications and Applicable Cabinet Width

| Item No. | Voltage | Power | Light Source | Color Temperature | CRI | (Working Temperature) | Sensor Switch | Connection |
|----------|---------|-------|--------------------------------|-------------------|-----|-----------------------|------------------------------------|--------------|
| 1291 | DC12V | 6W/M | COB 320PCS/M (single color) | 3000K/4000K | ≥90 | -20~+40° C | No (external connection available) | Dupont cable |

○ Installation View

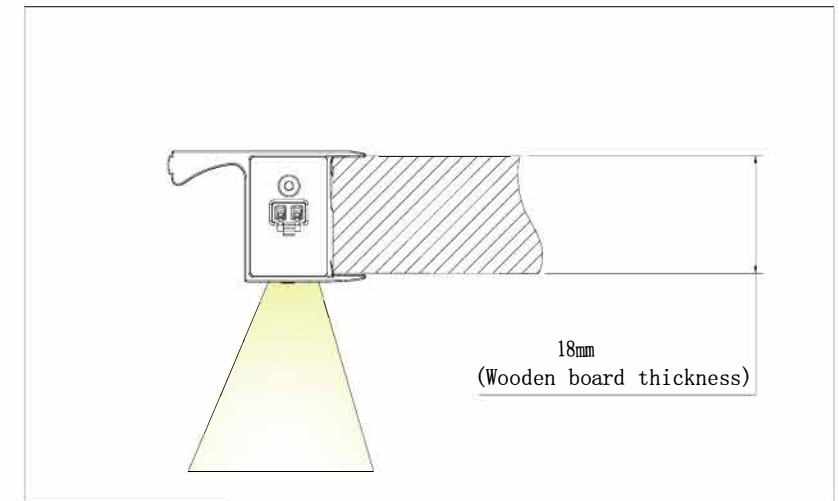

○ Installation Steps

